

Summary of Power Team's Activities—Fall 2007

Hamzah Sikander, Phillip Stathis, Gil Lee

Objective:

To complete the design and assembly of a robust power system for Cornell Minesweeper test bench robot: Spongebob. Power team successfully assigned batteries and a regulating circuit to suit Spongebob's needs.

I. Circuit Overview

This section defines the electrical schematic for creating a 24V line and 12V line, with two 12V batteries. We did not use a step up transformer.

Two concentric male power connectors are used to connect the battery to a barrier strip on a rail (See parts list for item descriptions). 16 AWG wires are used for all of the connections to make sure no melting occurs from high currents.

As shown in the schematic (Figure 1.1), the two batteries are connected in a configuration that produces two outputs, 12V and 24V. Both batteries are NiCd, meaning they can completely be discharged by applying a load to any of our two outputs. This is very beneficial for extending the

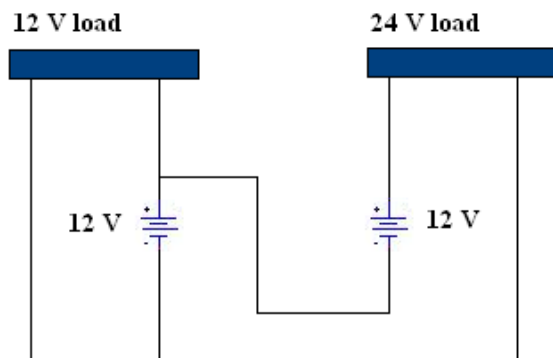

cycle of each use.

Figure 1.1: Schematic for Power System

A single output of 24V will be connected to the motors, and the 12V output will be connected to the ITX device that is housed within our robot. The downside with our design is that only one of the batteries is being depleted while a load is applied in the 12V output. This leaves the second battery completely out of use unless the 24V output is used.

This means that as soon as one of the batteries supplying 12V is depleted, there is no connection to supply 12V from the second battery. This is an issue with our power system, which we are looking forward to correct for Gladiator's power system. There are two reasons for ignoring it for Spongebob's system: investment in an inefficient and expensive step up transformer was not justified. Secondly, the power needs of the 12V source are around 60 W, where the motors needs are 120 W. Thus, both batteries will be depleted at the same rate, not leaving us at a disadvantage. Details about power consumption was part of the original design process.

II. Battery

A. Battery Specifics

The comparison chart below (Table 2.1) shows battery specifications for typical batteries of different types. While Li-ion batteries have the highest energy density, they are difficult to recharge. A NiMH battery has the next highest energy density; however, the internal resistance of the NiMH battery is, on average, 50% higher than for a similar NiCd battery. This indicates that when current flows through the battery, the heat dissipated in the battery is higher for NiMH than for NiCd batteries, which negates the advantage of higher energy density. The peak load current for a NiCd battery is 20C, which is significantly higher than those of other types of batteries. For example, a 1000 mAh battery can provide a peak current of 20 amperes. Also, the best result is obtained with a NiCd battery at 1C during continuous use. For autonomous robots, if the robot is stuck and the motors request more energy, the motors need to drain several amperes when they start accelerating, and NiCd batteries can accommodate for such current load spikes. Both NiCd and NiMH batteries have a flat discharge curve: the voltage only drops significantly when the capacity limit has been reached. This is important for our application, since the power provided by the battery hardly degrades as the battery's energy is consumed, and consequently, the motors can fully deplete the motors. Finally, NiMH batteries can be recharged, in general, fewer cycles than NiCd batteries.

Table 2.1: Battery Specifications

Type	NiCd	NiMH	Lead Acid	Li-ion
Energy Density (Wh/kg)	45-80	60-120	30-50	110-160
Internal Resistance (mW)	100-200	200-300	<100	150-250
Cycle Life (80% of initial)	1500	300-500	200-300	500-1000
Fast Charge Time (hr)	1	2-4	8-16	2-4
Overcharge Tolerance	moderate	low	high	very low
Load Current (Peak)	20C	5C	5C	>2C
Load Current (Best result)	1C	0.5C	0.2C	1C
Operating Temperature (°C)	-40 to 60	-20 to 60	-20 to 60	-20 to 60

For the purpose of IGVC model, peak load current and discharge rate along with optimal recharging capability were most needed. Evidently, NiCd batteries best fulfilled the specific requirement, which was the deciding factor of the battery selection of two 12V, 7Ah NiCd batteries.

B. Battery Recharging

Because a battery that is not properly charged will deliver sub-standard performance and display a shorter lifespan, recharging a battery is an important part of any power supply design.

The coulometric charging efficiency of a NiCd battery is about 83% for a fast charge rate (C to 4C), or 1.2C. The battery charger is supplied with the purchase of the battery.

III. DC-DC Converter

A. Introduction

The voltage of a battery declines over time as its stored power is drained. (Figure 3.1) Furthermore, the unregulated DC output from the batteries has a large noise factor, as illustrated on Figure 3.2. If unregulated, fluctuating voltage will cause problems to the motor functions. Because power directly depends on the output voltage, an unclear signal will produce a non-constant power and affect the motor control, resulting in an undesirable performance of the motors. Therefore, a 24V DC-DC converter is a crucial component of the circuitry as it will take the fluctuating signal of nominal 24V and feed out a clean, constant 24V signal independent of time. A 12V DC-DC converter is not needed because ITX device can internally regulate the signal by itself.

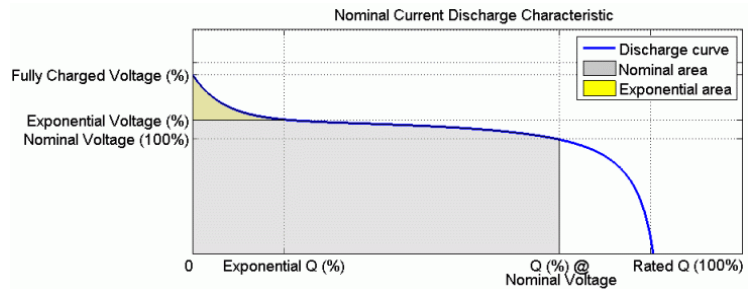

Figure 3.1: Voltage drop of a Battery

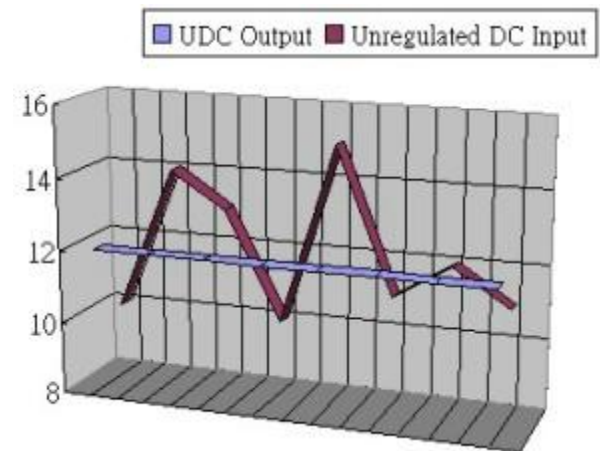

Figure 3.2: Noise factor of unregulated DC output

B. Requirements

The DC-DC converter must be able to receive an unclear 24V signal and feed out a clean 24V signal. Fully charged batteries will produce up to 26V while nearly depleted batteries will produce as low as 22V. Considering the noise factor, the unregulated output voltage may be greater than or less than the nominal 24V at a given time, ranging from about 20V-28V. This restriction requires the DC-DC converter to have a buck-boost mode, which is capable of switching from a step-up conversion mode to a step-down conversion as needed. For the same reason, the DC-DC converter also needs to tolerate a wide range of

input voltage. Following the power requirements of the motors, the DC-DC converter must tolerate up to 4A of current to supply 100W of power to the motors. In addition, the DC-DC converter should be placed before the 24V output line. A small, economical, efficient, and easily mountable DC-DC converter would be highly desirable. Finally, the DC-DC converter must have a proper surge protection.

C. Options

1. LT1070CT: Initially, cheap production cost and flexibility were the emphasis of the DC-DC converter selection. LT1070CT is a standard 5-pin switching regulator chip by Linear Technology (Figure 3.3) that, in conjunction with few external parts, can function as a DC-DC converter. Following the circuit construction and the formulas from the designer’s manual, the DC-DC converter circuit was built as shown by the schematic diagram, Figure 3.4.

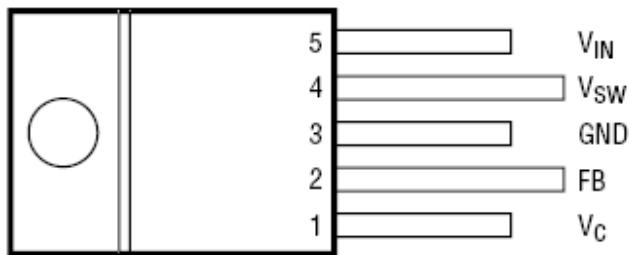

Fig 3.3: LT1070CT

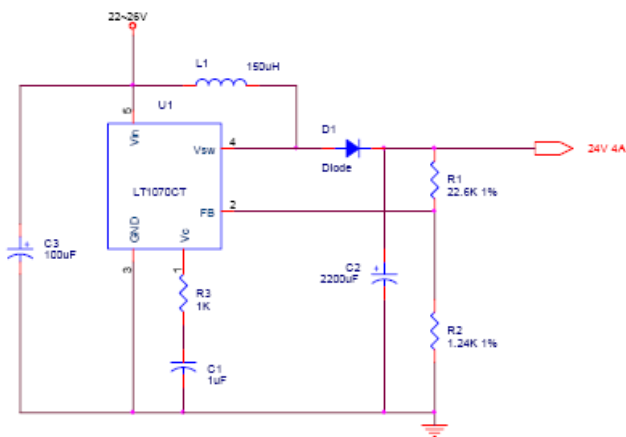

Fig 3.4: Schematic diagram with LT1070CT

The biggest advantages are cheap production cost and flexibility of the module. Each unit would cost at most \$35, which is significantly cheaper than the cost of an average custom-built DC-DC converter. More importantly, it would be possible to change

the specification of the converter by computing the values of the resistors, capacitors, and inductor according to the desired specification. However, whereas the chip itself is very small, the entire circuitry of the converter is rather large in size. Moreover, the difficulty and labor intensity of assembling the external parts, complications with the inductor and the calculations, and the difficulty of properly connecting and mounting the converter presented serious trouble in integrating the converter into the rest of the circuit that LT1070CT was discarded as a infeasible option.

2. VHB100-D24-S24: To eliminate the complications arising from self-assembly, a custom-made DC-DC converter was chosen. VHB100-D24-S24 is a half-brick style converter by V-Infinity (Figure 3.5) that eliminates the previous problems of LT1070CT. Although the benefit of flexibility is lost, the assembly of extra parts and manual calculation are no longer required. However, this converter does not present any easy or obvious measure for wire connection and physical installation. Most importantly, the converter demonstrated poor surge protection, which is essential to the overall protection of the power system. For these reasons, VHB100-D24-S24 was discarded as an impractical option.



Fig 3.5: VHB100-D24-S24

3. VDZ200-D24-S24: VHB100-D24-S24 is a fully enclosed converter by V-Infinity (Figure 3.6) that displays same specifications as VHB100-D24-S24 with few notable differences. First, the physical layout of the converter calls for easy connection and installation: the converter is mountable by screws in four corners and can be connected using solderless connectors. Also, the converter shows a very high efficiency of 88%, and the test confirmed that it has good surge protection and is thus safe to use. The only disadvantages of the converter are its relatively high cost and slightly bigger size compared to the previous model. VHB100-D24-S24 has been

integrated into the battery circuit as it is the best suited option.



Fig 3.6: VDZ200-D24-S24

4. SD-100B-24: As a back-up of VDZ200-D24-S24, SD-100B-24 was purchased as a cheaper alternative. SD-100B-24 is an enclosed converter by Mean Well (Figure 3.7) that demonstrates comparatively lower efficiency but at an extremely inexpensive cost. The converter provides virtually same specification as the previous options and offers screw terminal connection along with mounting clip and bracket for easy installation. However, the size of the converter is seven times the size of VDZ200-D24-S24. As smaller dimension and higher efficiency are currently of greater interest to the power system, the converter was not employed. It serves as a backup.



Figure 3.7: SD-100B-24

IV. Summary

The power team finalized the design of the power system and implemented it according to the robot's power requirements. The initial part of the design uses one of the 12V batteries to directly supply 12V to the ITX device, and the other battery is connected in series with the original battery to produce 24V for the motors.

DC-DC Converter Specifications

Part Number	LT1070CT	VHB100-D24-S24	VDZ200-D24-S24	SD-100B-24
Manufacturer	Linear Technology	V-infinity	V-infinity	Mean Well
Supplier	Digikey	V-infinity	V-infinity	TRC Electronics
Input Voltage	22-26 VDC	18-36 VDC	18-36 VDC	19-36 VDC
Output Power	96W	100W	120W	100W
Output Voltage	24VDC	24VDC	24VDC	24VDC
Output Current	4.0A	4.17A	4.16A	4.17A
Efficiency	-	85%	88%	83%
Size (L x W x H)	0.90 x 0.40 x 0.32	2.28 x 2.40 x 0.50	3.93 x 2.56 x 0.63	7.83 x 3.85 x 1.49
Cost	\$35.36	\$99.90	\$120.95	\$42.13